

# Parts & Service Manual

**Foremost Industries**  
**Model 400127-ES**  
(Extended Service)  
**Floating Cushion Sub**

## **Table of Contents**

<b>Page 3</b>	<b>Overview</b>
<b>Page 5</b>	<b>Schematic and Parts List</b>
<b>Page 7</b>	<b>Maintenance Schedules</b>
<b>Page 9</b>	<b>Maintenance Indicators</b>
<b>Page 13</b>	<b>Assembly &amp; Disassembly Procedures</b>
<b>Page 17</b>	<b>Rig Installation</b>

## Overview - Model 400127-ES Floating Cushion Sub

### General Specification

Hoist	200,000 lbs. Proof Load
Pulldown	200,000 lbs. Std. Cushion
Torque	35,000 lbs. / ft.
Extension	S-S Length extended 34.40 inches*
Retracted	S-S Length retracted 31.90 inches*
Stroke	2.5" with standard lower cushion
Weight	550 lbs.

\*Note: these lengths are maximum – shorter lengths are available.

A (max.)	12.00"
B	7.75"
C	7.50"
D	15.50"
E	31.75"
F (ext.)	2.50"
G (max.)	6.95"

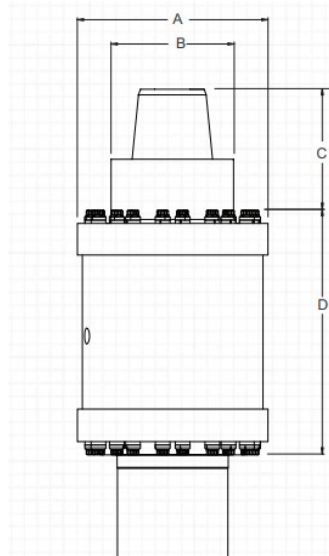

The 400127-ES (Extended Service) FCS is a modified version of the well proven 400127. Design enhancements greatly improve the retention of lubricating grease which allows for a reduction in routine greasing intervals in addition to longer running periods between major service intervals. The 400127 and 400127-ES retain many of the same components with overall dimensions being unchanged therefore, interchangeability between the models is easily achieved. Designed specifically to fit all rotary drills within a 100 Ton hoist capacity that are utilized to drill in soft to medium hard formations with either a tricone or DTH Hammer drilling method. When mounted into the drive spindle of the gear box it will provide a minimum of two and one half (2 1/2) inches of free travel between the top of the drill string and the rotary drive. The extended stroke enables the drill operators to quickly and easily make-up and breakout connections on the drill pipe with minimal thread damage. When the rotary drive is lowered to pick up on the threads of the drill pipe, the piston component of the cushion sub will slide up into the body of the assembly which will

considerably lessen the impact not only on the threads of the drill pipe but also the bearings and gears retained within the rotary drive. The shock and vibration transmitted by the DHA are reduced significantly by incorporating urethane cushions at the top and bottom of the piston stroke in addition to some hydraulic dampening from within the housing cavity. These factors all enhance the drills performance and decrease maintenance when using either pull-down or hold back methods for drilling.

The Foremost Cushion Sub will accommodate drill string combinations up to and including seven (7) inches in diameter. Typically, the assembly is supplied with a pin up / box down thread combination cut to customer specifications. The cushion sub assembly has been configured to fit mid-range drills so as not to interfere with the operation of the backup wrench and to allow the operator to install the unit without any modifications to the drill. In most cases, there will be room in the mast to install a short saver sub below the cushion sub to make up the required length as per the original extended sub supplied by the drill manufacturer. Seals, cushions and other wear parts can be easily replaced in your own facility as no special tools or equipment are necessary for dismantling and rebuilding the complete assembly. Lubrication of internal components to reduce wear and prevent corrosion within the housing is accomplished by means of a grease fitting conveniently located on the outside diameter of the body.

## Features

1. Sliding spindle with 2 ½” inches of extension.
2. Standard seals, wipers and wear rings are utilized to isolate drilling fluids and air.
3. Unique drive system to transfer rotary torque to the drill string.
4. Precision machined components manufactured from high strength alloy steel.
5. Manufactured to suit O.E.M. drill specifications.
6. Large through bore in a stationary Wash Pipe assembly.
7. Heavy duty urethane upper and lower cushions.

## Benefits

1. Sliding spindle reduces thread damage to drill pipe and allows drill operators to quickly and easily make-up and breakout connections.
2. Reduced maintenance to rotary drive bearings and gears.
3. Repairs and rebuilds can be accomplished with common tools.
4. Axial vibration are drastically reduced.
5. No modifications to the backup wrench or drill are required.
6. No restriction of air flow to the bit.
7. Maintenance costs on the drill and drilling tools are greatly reduced.

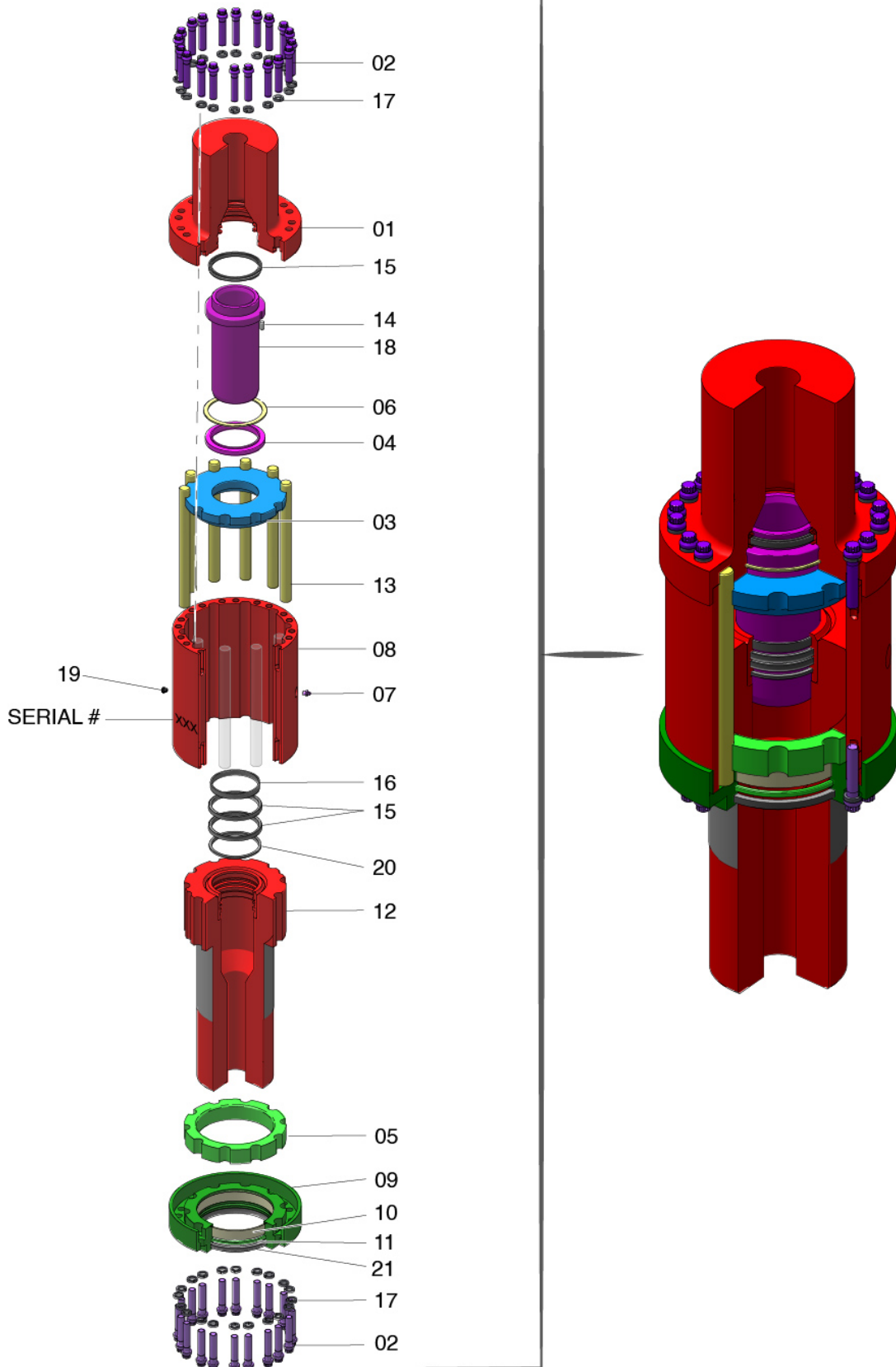

## Model 400127-ES Floating Cushion Sub Parts List

Item No.	Part No.	No. Req'd	Description
1	398935	1	Upper Cap – (Blank)
2	310422	40	Cap Screws Modified
Ref	9138-00-3535	40	Cap Screw Unmodified
3	398964	1	Upper Cushion
4	307208	1	Spacer Ring
5	399062	1	Lower Cushion 1.5”
Ref	401291	1	HD Lower Cushion 2.5”
6	16-38-289797	1	Retaining Ring
7	9285-00-0610	1	Grease Fitting
8	398968	1	Body
9	399003	1	Lower Cap
10	357201	1	Wear Ring
11	357200	1	Seal
12	398999	1	Piston - (Blank)
13	399061	10	Drive Pins
14	398954	1	Washpipe
15	307249	3	Seals
16	307245	1	Wear Ring
17	9678-00-0280	40	Lockwashers
Ref	416498	40	Lockwashers (High Capacity)
18	395632	1	Locating Pin
19	5680	1	Relief Fitting
20	307246	1	Wiper Ring
21	357202	1	Wiper Ring
Pt. No.	400127-30-ES	1	Seal Kit (4,6,10,11,15,16,18,20,21)
Pt. No.	400127-31-ES	1	Seal & Cushion Kit (3,4,5,6,10,11,15,16,18,20,21)

Note: The list above is for the standard configuration assembled with blank upper cap and piston (no threads cut). Please contact Foremost and provide Serial # to determine any assembly options and thread configuration.

---

## Maintenance Schedules

### **Routine Service Intervals:**

During factory assembly 725\* grams of grease has been installed into the housing for lubrication of the internal components. For optimal life between major service intervals, under average operating conditions, add 15\*\* grams of grease (10 – 15 pumps from a typical handheld grease gun\*\*) every 7-10 days or approximately every 150-200 operating hours. Pending the parameters of the drilling application and conditions it may be necessary to increase or decrease greasing intervals. Failure to maintain sufficient levels of grease will void warranty.

\*400 grams for FCS with HD lower cushion installed – reduces stroke to 1”.

\*\*For reference a typical lever-style grease gun disperses 1.28 grams of grease per pump while the hand-grip style disperses 0.86 grams per pump.

A synthetic grease that meets standard NLGI #2 GC-LB should be used.

As an alternative it is acceptable to use an EP lithium grease meeting NLGI Grade 2 standard.

When high operating temperatures are present, it may be necessary to grease the cushion sub on a more frequent basis or utilize a higher temp grease.

The grease fitting is located in the approximate center position of the main body. Grease should be installed when the sliding spindle is in the retracted or up position.

It is possible to over grease the FCS. One indicator of excess grease is reduced float of the piston. Ideally there should be approximately 1” to 1 ½” (25-40 mm) of up and down travel of the piston when the assembly is operating.

If at any time the piston will not retract or extend from the housing, there could be too much grease in the body cavity. If this happens, remove the grease fitting and cycle the spindle up and down several times to remove excess grease and then re-install the fitting into the body. Use extreme caution when cycling the spindle up and down with the grease fitting removed as grease may be expelled under pressure. Wait one service interval before beginning the lubrication cycle again and adjust the amount and or the frequency of grease being added. The specific drilling application and conditions will determine the optimal quantity and frequency of routine service.

## Major Service Intervals:

Periodically it will be necessary to replace seals and other wear items in the assembly. The frequency of this maintenance will depend upon the drilling application and the amount of lubrication the unit receives during its operating cycle. If at any time during the drilling operation, air or fluids are being blown past the piston seal on the lower end of the body, the cushion sub should be removed immediately from the drill to have a new seal kit installed.

Operators or maintenance personnel should perform an initial inspection based on the drilling conditions below and adjust ongoing service intervals accordingly.

	Formation Type		
Foremost Model 400127ES	Soft - Medium	Med - Hard	Hard - Extreme
Rotating Hours	1500	1000	750

To insure optimal performance and product life, maintenance personnel over time should establish a routine whereas the FCS is rotated in and out of service at intervals established by the specific drilling application and conditions.



## Maintenance Indicators

A spline drive system transfers the torque from the rotary spindle to the drill string and the bit by means of drive pins located between the housing cavity and piston. Upper and lower cushions are used to absorb the shock displaced into the piston from the drill string when the piston is either at the upper or lower limits of its stroke within the housing. Drilling fluids/air are isolated from the housing by means of a washpipe and seal arrangement preventing corrosion from taking place on the internal components.

The severity of the drilling application will determine the cycle time in which the cushion sub may require having some internal components replaced. The following are some visual indicators as to when the cushion sub should be removed from service and a rebuild performed:

1. If air or drilling fluid is being blown out around the wiper seal at the lower end of the assembly around the piston. (likely cause - leaking seal at the washpipe)
2. If the piston seems to have more extension than when the cushion sub was originally installed on the drill.
3. If backlash in the piston and housing is excessive (the time between when the rotary spindle starts to rotate and the drill steel starts to rotate).
4. If piston runout in relation to the housing is greater than 1/8" (3mm) the lower wear ring should be replaced.

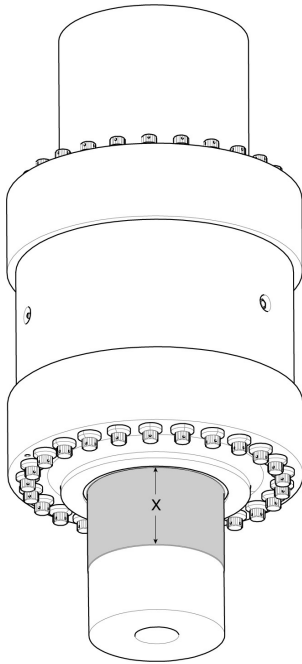

When new, the chrome section on the piston when fully extended, will protrude  $X = 3.90''$  (10 cm)\* below the lower cap.

\*(2.90'' (7.4 cm) with HD lower cushion installed)

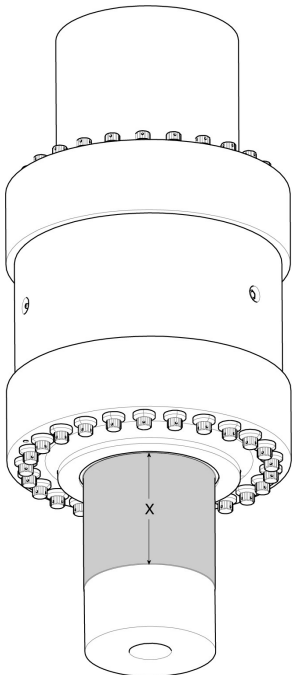

If the chrome section on the piston when fully extended exceeds  $X = 4.40''$  (11.2 cm)\* below the lower cap, the lower cushion should be replaced as soon as possible.

\*(3.40'' (8.6 cm) with HD lower cushion installed)

**Note: Some models have been assembled with a HD lower cushion reducing stroke by 1'' (2.5cm). Standard stroke is 2 1/2'' (6.3 cm).**

The splines in the piston and the housing will eventually start to wear due to the torsional pressure being applied during the drilling process from the bit and also from making up and breaking out of threads creating excessive free play (backlash).

To check the amount of free play, restrain the lower connection (piston) and rotate the upper connection with a force of 10 - 20 ft/lb until rotation stops.

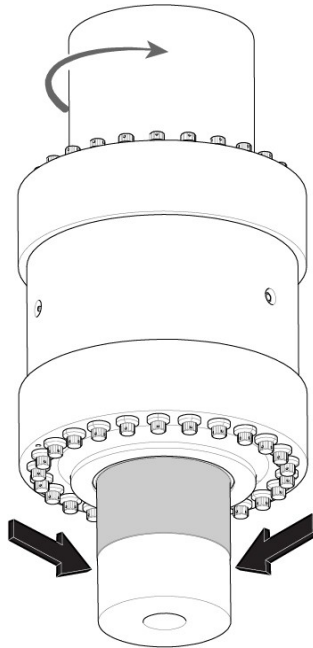

Mark a position on the piston and the lower cap parallel with each other.

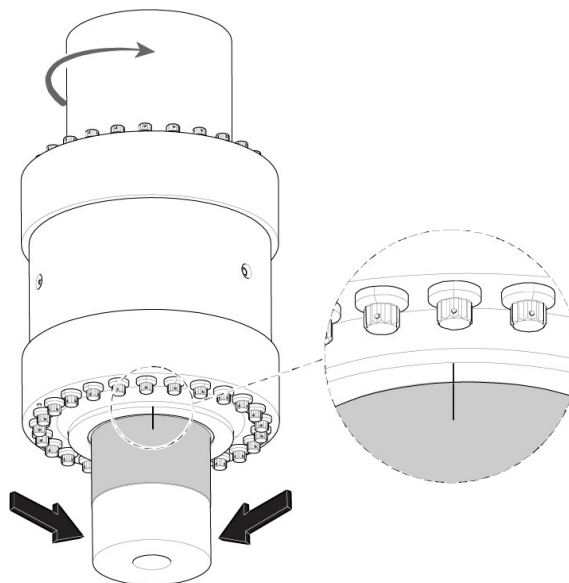

Restraint the lower connection (piston) and rotate the upper connection in the opposite direction with a force of 10 - 20 ft/lb until rotation stops.

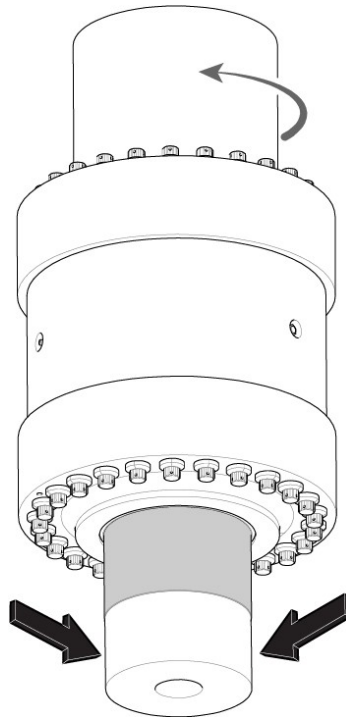

Measure the distance between the lines. When the free play exceeds 1/2" (1.27cm) - the piston and or body may need to be replaced.

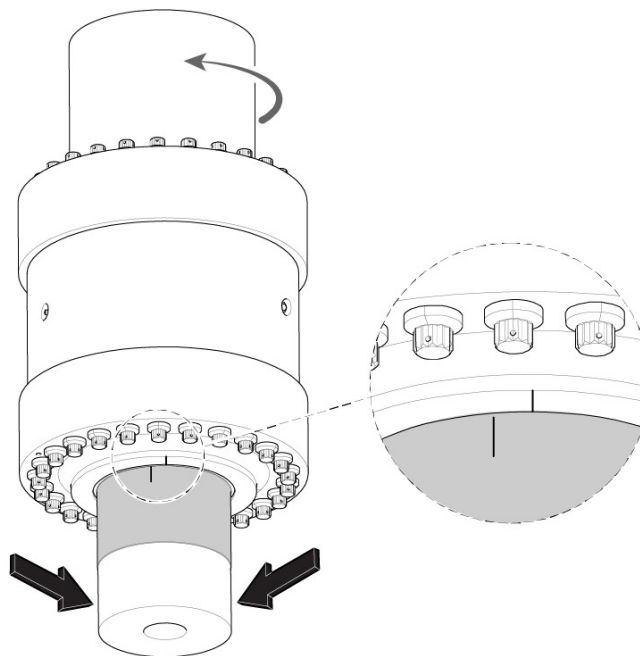

## Assembly and Disassembly Procedures

### Disassembly

1. Securely clamp the Cushion Sub in a vertical position to a work bench with the piston in the up position.
2. Remove Cap Screws and lock washers (20) from the Lower Cap. (Item #2)
3. Remove Lower Cap from the Body. (Item #8)
4. Remove Lower Cushion (Item #5) from the Body.
5. Thread a lift nubbin into the thread of the piston and using a hoist, pull the Piston (Item #12) out of the Body and secure it on the work bench.
6. Rotate the Cushion Sub to re-position the remaining assembly with the Upper Cap in the up position and securely clamp it to the work bench.
7. Remove Cap Screws and lock washers (20) from the Upper Cap (Item #1)
8. Thread a lift nubbin onto the thread of the upper cap and use a hoist and rubber mallet to separate the Upper Cap from the Body.
9. Remove Upper Cushion (Item #3) from the Body.
10. Secure the Upper Cap assembly to the work bench to remove Spacer (Item #4) and the Washpipe (Item #14) from the Upper Cap
11. Using Snap Ring pliers, remove Retaining Ring. (Item #6)
12. Remove Washpipe from the Upper Cap.
13. Remove Seal from the Upper Cap. (Check for corrosion and wear in the seal groove)
14. Remove Seals, Wiper Rings and Wear Rings from Piston and Lower Cap (check for wear)
15. Clean all parts with cleaning fluid and inspect for wear and corrosion in seal areas - deburr any parts and remove sharp edges prior to assembly.
16. Seals, Guide Rings and Cushions can be replaced by purchasing a Seal and Cushion Kit Part # 400127 – 31-ES (Item #3,4,5,6,10,11,15,16,20,21)

### Assembly

1. Place one Seal (Item#15) in the seal location fit of the Upper Cap (Item #1)  
The seal should be located with the O-ring side in the up position.
2. Insert the Washpipe (Item #14) in the location fit within the Upper Cap.
3. Install the Retaining Ring into the groove. (be sure it is properly seated)
4. Install Spacer over the Washpipe to seat in the location fit.
5. Relocate the Upper Cap assembly onto the body.
6. Install Hi-Collar Lock Washers on the Cap Screws, apply Loctite to cap screw threads (see notes below) and install through the Upper Cap and into threads of Body. Torque Cap Screws to 210 ft. lbs.
7. Secure the Upper Cap and Body Assembly in a vertical position.
8. Reach in through the Body and install the Upper Cushion over the Washpipe.
9. Install the Piston after replacing the seals, wiper ring and guide ring.
10. Lubricate the drive pins and body (recommend the use of a Synthetic Grease however if it is not available a Unirex Moly H grease or equivalent is acceptable)
11. Install Lower Cushion (Item #5) into the Body approximately 1" below the end.
12. Install the Lower Cap (Item #9) into the location fit of the Body (line up bolt holes)

13. Install Hi-Collar Lockwashers on the cap screws, apply Loctite to threads and install into the Body.
14. Torque Cap Screws to 210 ft. lbs.

Note: Only fully qualified individuals should attempt to rebuild the cushion sub. All company safety rules and regulations should be followed during this process.

**Notes:**

- Under no circumstances should any welding or wrenching be done on the chrome surface of the spindle.
- If cap screws are seized, heating maybe required to free thread locking compound. Do not exceed 200 degrees F in any portion or components of the assembly.
- There are optional methods used when installing the Capscrews

## Capscrews Installation:

### Standard Method – Capscrew with thread locking compound:

- Cap screws are coated with thread locker  
[https://www.henkel-adhesives.com/ca/en/product/threadlockers/loctite\\_2630.html](https://www.henkel-adhesives.com/ca/en/product/threadlockers/loctite_2630.html)
- Torque capscrew to 210 ft/lbs – alternating across the bolt circle
- Secure with lock wire. Follow Foremost Lock Wire Procedure document # 387100

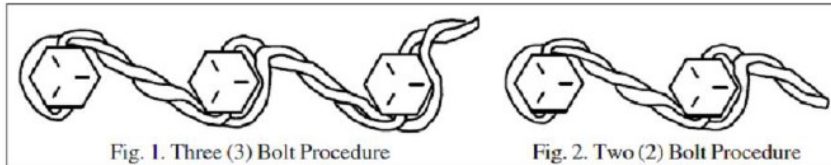

THE FOLLOWING PROCEDURE IS TO BE USED WHEN DRILLING BOLT HEADS OR SECURING BOLTS WITH LOCK WIRE. (REF MACHINERY'S HANDBOOK 26TH ED) THIS APPLIES TO GRADE 5 AND 8 HEX HEAD OR SOCKET HEAD BOLTS OF EITHER UNC OR UNF THREADING

THE USE OF SAFETY WIRE TIES IS ILLUSTRATED IN FIG. 1 & 2. THE ILLUSTRATIONS ASSUME THE USE OF RIGHT-HAND THREADED FASTENERS AND THE FOLLOWING ADDITIONAL RULES APPLY:

1. NO MORE THEN THREE (3) BOLTS MAY BE TIED TOGETHER
2. BOLTS HEADS MAY BE TIED AS SHOWN ONLY WHEN THE FEMALE THREAD RECIEVER IS CAPTIVE
3. PRE-DRILLED NUTS MAY BE TIED IN A FASHION SIMILAR TO THAT ILLUSTRATED WITH THE FOLLOWING CONDITIONS.
  - A. NUTS MUST BE HEAT-TREATED AND
  - B. NUTS ARE TO BE FACTORY DRILLED FOR USE WITH LOCK WIRE
4. LOCK WIRE MUST FILL A MINIMUM OF 75% OF THE DRILLED HOLE PROVIDED FOR THE USE OF LOCK WIRE
5. LOCK WIRE MUST BE AIRCRAFT QUALITY STAINLESS STEEL. DIAMETER OF LOCK WIRE IS DETERMINED BY THE THREAD SIZE OF FASTENER; SEE TABLE 1
6. THE LARGER WIRE MAY BE USED IN SMALLER BOLTS IN CASES OF CONVENIENCE, BUT SMALLER WIRE MUST NOT BE USED IN LARGER FASTENER SIZES.
7. DRILLED HOLE IS TO BE LOCATED ON THE AXIS OF THE BOLT AT A DISTANCE FROM THE TOP OF THE HEAD OF THE BOLT EQUAL THAT ILLUSTRATED IN FIG. 3

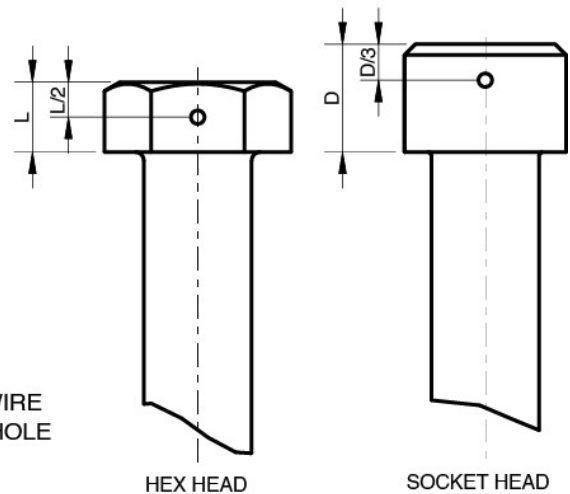

FIGURE 3. DRILLED HOLE LOCATION

FASTENER SIZE	WIRE DIA.	DRILL BIT
< $\phi$ 1/4"	0.020"	#72
$\phi$ 1/4" - $\phi$ 1/2"	0.032"	#60
> $\phi$ 1/2"	0.042"	1/8

TABLE 1: WIRE AND DRILL SIZE GUIDELINE

Optional Method #1– Cap screw & High Capacity lockwasher:

- Cap screws are coated with thread locker  
[https://www.henkel-adhesives.com/ca/en/product/threadlockers/loctite\\_2630.html](https://www.henkel-adhesives.com/ca/en/product/threadlockers/loctite_2630.html)
- Install high capacity lockwashers  
[https://www.heico-group.com/en/heico-lock/products/ring-lock-washers/?file=files/hc/pdf/pdf\\_en/HEICO-LOCK-Assembly-Instructions-EN\\_012018.pdf&cid=2798](https://www.heico-group.com/en/heico-lock/products/ring-lock-washers/?file=files/hc/pdf/pdf_en/HEICO-LOCK-Assembly-Instructions-EN_012018.pdf&cid=2798)
- Torque capscrew to 250 ft/lbs – alternating across the bolt circle

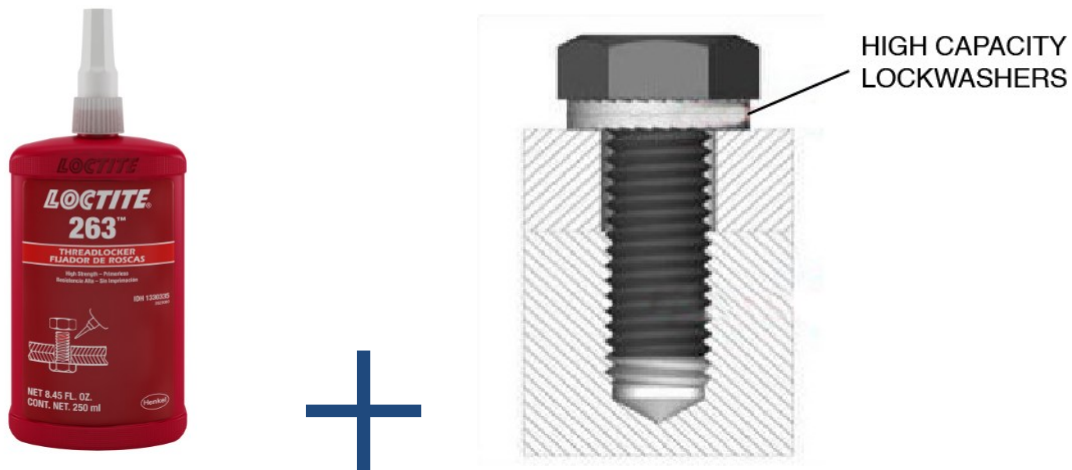



## Rig Installation

In most applications when installing the FCS making up the threaded connection to the specified torque requirements of the particular thread is sufficient to prevent backing off when breaking away from the drill string. However, in some cases additional means of retention are desired. There are several options available to assist further retaining the treaded connections.

### Thread Locking Compounds

<https://bakerlok.com/>

<https://forumlok.com/>

<https://www.jetlube.com/product/jet-lok-iii-threadlocker-two-part-epoxy>

### Mechanical Locking Systems

<https://www.foremost.ca/foremost-mobile-equipment/mining-drill-tooling/variable-range-tool-joint-clamp/>

#### Description

The Tool Joint Clamp consists of a split hub, tong dies and cap screws all of which are manufactured from alloy steel, heat-treated for maximum strength and gripping ability. Each assembly is machined to incorporate tong dies held in a dove tail groove machined the entire length of the hub. Cotter pins at each end of the tong die prevent the die from falling out of the assembly. The high strength cap screws equally spaced vertically along each side of the hub are tightened to displace the clamp force evenly along the entire length of the tong die. The gripping pressure of the clamp will prevent the threaded tool joints from backing off.

#### Installation

Apply the proper thread compound to the tool joints and make up the threads to the suggested API torque. Remove the cap screws from the assembly and separate the two halves of the clamp. Position the two halves to centralize the assembly vertically around the shafts at the point where the tool joints shouldered together. Begin to tighten the cap screws alternating at 180 degrees to maintain even pressure on each side of the clamp applying force against the outside circumference of each shaft as the cap screws are tightened.

Note: Apply specified torque and Locktite 242 to all Capscrews  
CAPS HEX SOCKET UNC 3/4" X 3" - TORQUE 376 FT LBS  
CAPS HEX SOCKET UNC 1/2" X 2-1/2" - TORQUE 103-105 FT LBS  
CAPS COUNTERBORE 5/8" X 2 1/2" - TORQUE 212 FT LBS

01	CLAMP - TOOL JOINT	1
02	DIE-TONG 3 1/2 LG MACH	4
03	CAPS HEX SOCKET HD NC 3/4" X 3"	8
03	CAPS HEX SOCKET UNC 1/2" X 2-1/2"	8
03	CAPS COUNTERBORE 5/8" X 2 1/2"	12
04	WASHER - LOCK HIGH COLLAR 1/2	8
05	PIN-COTTER 1/8 X 1	8

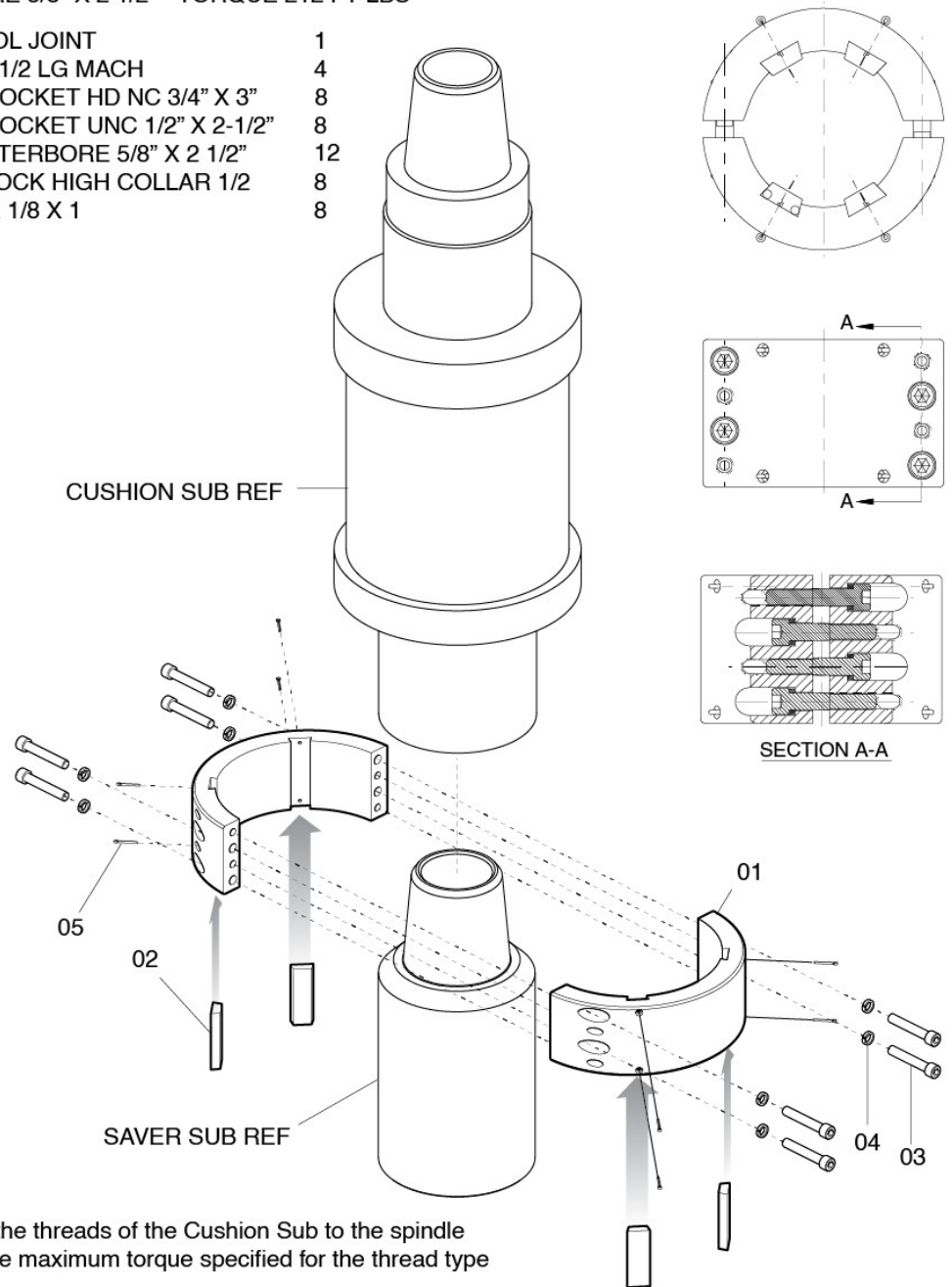

Engage and make up the threads of the Cushion Sub to the spindle and or Saver Sub to the maximum torque specified for the thread type

#### Clamp Installation

- 1: Align clamp so as to straddle the tool joints to be secured
- 2: Apply Locktight 242 to cap screws and threaded holes in the clamp
- 3: Install the lock washers over the cap screws, insert and engage all of the cap screws in the corresponding threaded holes of the split clamp
- 4: Alternate tightening the cap screws until each of the threads are fully engaged
- 5: Once all cap screws are fully engaged, torque the cap screws to the recommended value for the screw size

Disclaimer Foremost urges adherence to the function, maintenance, operation and rebuild of the Floating Cushion Sub outlined herein. Foremost recommends taking your product to an experienced, qualified service center for maintenance and repair. Failure to follow the information herein may result in damage to the product or facility, unsafe conditions, injury to user and/or any warranties being voided. Foremost has no control over the end use of the product or the environment into which the product is placed or operated in.

Foremost encourages the safe use of its products. To help avoid personal injury or damage to the product:

1. Wear approved personal protection equipment, including eye, ear, head, and foot protection.
2. Inspect the product before each use. If the product is cracked, burred, bent, or damaged in any way, **DO NOT USE IT.**
3. Use the product within the operating parameters.
4. Stand clear of the product while in use and make sure protective guards are in place.
5. Maintain product in accordance with the maintenance schedule herein.
6. Exercise care when disassembling and assembling the product.

**THE INFORMATION INCLUDED IN THIS DOCUMENT HEREIN IS ONLY ADVISORY IN NATURE AND DOES NOT CONSTITUTE ANY REPRESENTATION OR WARRANTY ON BEHALF OF FOREMOST.**